



## 32V and 40VDC Series Brushless Screwdrivers - Operation Manual



Applies to the following Delta Regis products:

**32VDC Screwdriver Models:** CESL810(S)/811/812(P/S)(-ESD),  
CESL823/824(F/P/PF/S)(-ESD)(/RA), CESL827B(P)(-ESD)(/RA)

**40VDC Screwdriver Models:** CESL828/829(F/P/PF/S)(-ESD)(/RA),  
CESLT835M/845M/855M/865M(PM)(-ESD)(-SQ) (RA)  
CESLT875M(PM)(-SQ)(/RA)/885M/895M(PM)(-SQ)  
CESP(T)835/845/855/865(-SQ)(-U)  
CESLT935(F/P/PF)(-ESD)(-SQ), CESLT945/955(P)(-ESD)(-SQ)

**32VDC Controller Models:** BECT620C/820

**40VDC Controller Models:** BECT640HL/940HL

**CAUTION** - Please read, understand, and follow all operating and safety instructions in this manual before using the tools and controllers.

The CESL8 and CESL9 Series Brushless tools are designed for exclusive use with specific Delta Regis controllers as defined in this manual. Do not attempt to use the tools and/or controllers with any products other than as specified in this manual.

**If you have any questions or concerns,  
please contact us at:**

**Delta Regis Tools, Inc.  
7370 Commercial Circle  
Fort Pierce, FL USA 34951  
Ph +1-772-465-4302  
Fx +1-772-465-4368  
E-mail: [sales@deltaregis.com](mailto:sales@deltaregis.com)**

## Important - Installation and Safety

**Warning - Failure to understand and follow proper installation guidelines, safety requirements, and operating instructions may result in malfunction, component damage, property damage, shock hazard, fire hazard, injury or death.**

1. Please read and understand the operation manual and follow all safety and operation instructions.
2. Use these products in a suitable dry, indoor location. Do not use the tools and controllers in damp, wet or high temperature environments. Do not use in the presence of flammable liquids or gases.
3. Ensure that the controller has proper ventilation. Do not expose the tools and controllers to areas subject to airborne contaminants (eg. dust, metal filings).
4. Use only a properly grounded electrical outlet of the correct supply voltage to power the screwdriver controller.
5. Ensure that the supply outlet is overload protected and of sufficient amperage capacity.
6. Use only the correct plug for the controller and outlet. Hold the plug of the power cord when connecting or disconnecting. Do not pull on the cable.
7. Do not expose the cable, tool or controller to oil, chemicals, or heat. Ensure that the cable is routed and used in such a manner as to not be subject to sharp objects that may abrade or cut the cable.
8. Locate the controller in a suitable, safe location on a steady surface. Do not place in a high location where there may be a risk of it falling. Secure the controller in position to prevent possible movement caused by pulling on the power or tool cables.
9. Do not cover the controller or stack any objects on top of or near the controller. Ensure that adequate clearance and ventilation is provided around the perimeter of the controller.
10. Specific models of Delta Regis BECT series controller are designated for use with CESL8 and CESL9 series screwdrivers as specified on the following pages. Use of the controller (or screwdriver) with any other screwdriver (or controller) may result in malfunction, damage, or injury.
11. In the event that the controller is overloaded beyond the maximum current rating, an internal fuse will disrupt power. Should the controller stop functioning, or exhibit abnormal or intermittent operation, please discontinue use immediately and send the controller to an authorized service centre for troubleshooting and repair.
12. Excessive duty cycle will cause the tool and/or controller to overheat. If this occurs, discontinue use until cooled down and reduce cycle rate. As a general rule, do not exceed 10-15 screws/minute, one 8 hour shift per day.
13. The CESL8 and CESL9 series screwdrivers incorporate a protection circuit which stops the electric screwdriver if the tool is switched from forward to reverse while running. Should this happen, the operator must release the tool trigger and restart the fastening cycle.
14. Power the controller off and wait for 3 seconds before connecting/disconnecting the screwdriver tool cable to/from the controller.
15. Turn the main power switch off when the controller is not being used. Unplug the controller if it is not being used on a regular basis.
16. Do not attempt to disassemble or repair the screwdriver or controller. Repairs should only be performed by qualified technicians properly trained in the safe operation, troubleshooting, and repair of these devices. Please consult Delta Regis for the location of the nearest service depot.
17. Use only the factory specified Delta Regis brand replacement parts and accessories with these tools and controllers.
18. Any damage to the tool and/or controller resulting from misuse, abuse, or failure to follow these guidelines will void the limited product warranty.
19. Do not dispose of electrical appliances as unsorted municipal waste, use separate collection systems available. If electrical appliances are disposed of in landfills or dumps, hazardous substances can leak into the groundwater and get into the food chain, damaging your health and well-being. When replacing old appliance with new, the seller is legally obligated to take back your old appliance for disposal free of charge.



20. We emphasize that the power supply should be placed on a flat surface and secured. The power supply label/specifications are located on the bottom of the most models. Place on a flat surface and use a M4 x 20mm screw to align the anchor hole and secure it to the flat surface.

**Grounding** - This controller (and AC power cord) is equipped with a 3-prong electrical receptacle/plug with ground pin. The controller must be connected to a properly grounded AC electrical outlet. Do not attempt to use this controller without a properly functioning ground connection. Never connect a live circuit to the ground pin or internal yellow-green ground wire.

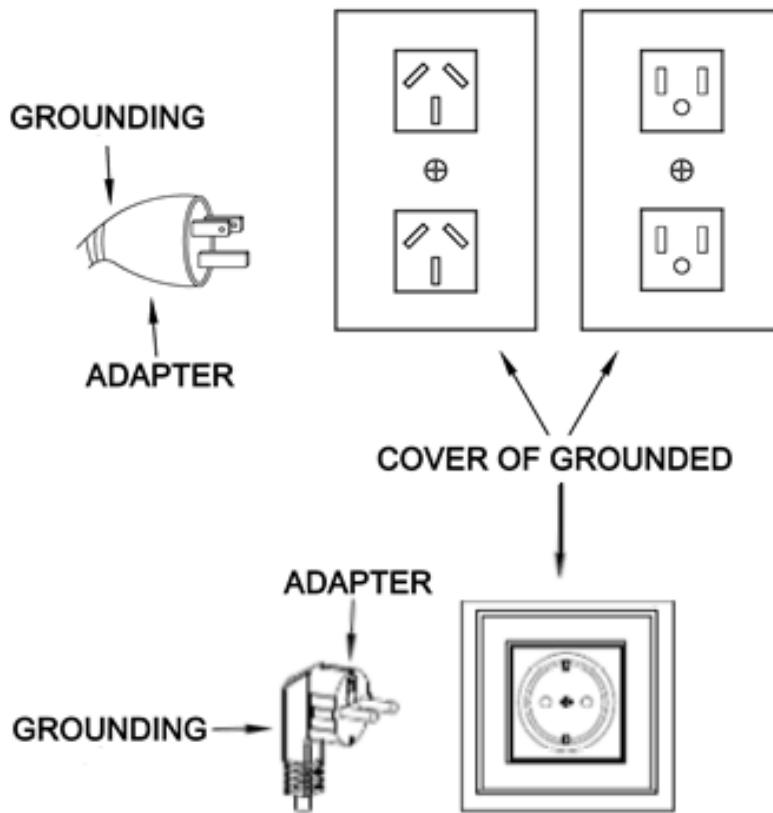

### Setting up your screwdriver and controller

Unpack the tool and controller from their boxes and confirm that all items have been received and are in good condition. The controller is shipped with the appropriate grounded power cord for connection to the AC supply receptacle. The screwdriver is shipped with a 2 meter tool cable that connects the screwdriver to the controller. CESLT8..M/PM, CESLT9 and CESP8 pistol housing tools also include an accessory side handle.

Select a suitable, stable location for the controller. Ensure that the location allows for the required range of motion of the screwdriver without stressing the tool cable that connects the tool to the controller. The cable should bend naturally and always have some play in it. Undue stress put on the cable will result in premature cable failure. If the standard cable length is unsuitable, longer lengths are available for purchase as an option.

If the tool is being mounted in a fixture or torque arm, mount the tool in the arm. 'M' series tools incorporate an aluminum mounting surface directly in front of the tool grip/housing nut. Please use this surface for fixturing. Fasten the tool securely to avoid it rotating in the fixture due to reaction torque. An optional metal torque lock sleeve is available for some models to aid in mounting in a torque arm.

We recommend that all higher torque CESL8/9 screwdrivers be mounted in a torque arm to isolate the operator from the reaction torque generated by tools in this torque range. If it is necessary to use a CESLT8..M or CESLT9 series in-line tool without a reaction arm, the accessory side handle must be installed and used by the operator to react torque.



Accessory Side Handle included with models CESLT8..M/PM and CESP8..

Always install and use for handheld applications to react torque.

Aluminum surface for fixture mounting



The CESLT8..M/PM and CESP8.. screwdriver housings include a groove for installation of the side handle. Ensure that the notch in the handle is aligned properly with the groove and fasten securely.

Ensure that the controller's power switch is in the 'off' position. Connect the 6-pin tool cable to the screwdriver. The cable has a spring guard at one end for added protection and durability. Plug this end of the cable into the tool. The connector is designed to be a tight fit - seat the connector firmly into the receptacle and tighten the nut securely by hand. Attach the other end of the cable to the controller in the same manner. Plug the supplied power cord from the controller into a suitable, properly grounded AC receptacle.

Screwdriver end of cable includes spring guard for added durability



Push cable connector firmly into receptacle and secure retaining nut hand-tight. Do not overtighten.



32VDC 6-pin CESL8 Series Tool Connector



40VDC 6-pin CESL8/9 Series Tool Connector

**Always turn off controller power and wait 3 seconds before connecting or disconnecting the screwdriver cable. Do not connect/disconnect the screwdriver with the power supply turned on.**

## Before you turn on the controller

Insert the desired screwdriver bit into the quick change holder of the driver. For tools with 1/4" hex bit holders, insert the desired driver bit by pushing (or pulling, depending on the model) the outer sleeve of the bit holder to release the retainer. Insert an appropriate power bit, release the sleeve and ensure that the bit is properly locked in place by pulling back and forth on the bit.

Make sure that the tool's start mechanism (lever, trigger, or push-start) is not engaged to prevent the tool from accidentally starting when turning on the controller's power switch. Turn the controller's main power switch on. Select the desired speed (Hi/Low) of the screwdriver via the speed switch on the controller.



## Operating the screwdriver

Depending on the model of screwdriver selected, the screwdriver will have either a start lever, a push-to-start mechanism (models with 'P' suffix), or a trigger start (pistol grip models). All models also have a forward/reverse switch.

Grip the screwdriver so that the index finger is comfortably over the trigger mechanism and the thumb can be used to change the position of the fwd/rev switch if required. Hold securely to prevent the screwdriver from rotating in your hand during use.

If the tool has a side handle installed, grasp the side handle firmly with the other hand. Due to the torque output capabilities of some models, it is extremely important to use the supplied side handle in all handheld applications and to grip the tool firmly to react the torque. Familiarize yourself with the operation of the tool by free running the tool before use at higher torque values.

Align the driver bit properly with the head of the fastener. Keeping the driver in-line with the fastener, activate and hold the start mechanism (lever, trigger or push). The screwdriver will install the fastener (FWD). When the preset torque is reached, the clutch will activate and the tool will shut off. Once the tool shuts off, release the start mechanism to reset. To stop the screwdriver before fastening is complete, release the start mechanism.

To remove a fastener, change the FWD/REV switch to the REV position. Press the start mechanism to run the driver in reverse (CCW). Do not switch from forward to reverse (or reverse to forward) while the motor is running. A protection circuit will stop the tool if it is inadvertently switched while running - if this happens, the trigger must be released and re-activated to continue operating.



## Setting the torque

An external torque adjustment nut located at the nose of the screwdriver is used to set the output torque of the screwdriver. **A reference scale (0-8) is available as a guide - this scale is for reference only and does not indicate actual torque values.** Rotate the torque nut clockwise to increase torque output, ccw to decrease torque output. Make the torque adjustment through a series of gradual increases, starting below the desired torque level. We recommend the use of an appropriate torque tester and static joint testing after installation to verify proper torque settings.

Once the torque is set, remove the housing nut and cover the torque adjustment nut with the included torque lock sleeve (CESL810-829, CESLT8\_M, CESPT8 models). This will help avoid accidental torque adjustments.

The torque output of the screwdriver should be verified on a regular basis. Frequency of verification will depend on the customer's specific application and quality control requirements. During the initial screwdriver break-in period, output torque may decay somewhat as the mechanical components wear in.

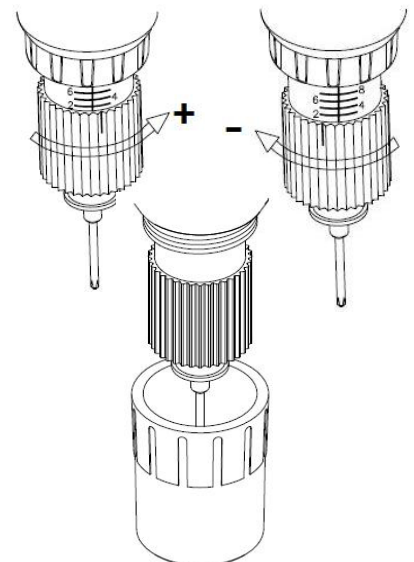

## Torque Reference Charts

### Important Note

The charts below are provided to assist in setting your screwdriver to an approximate torque value. Actual results may vary from tool to tool. In order to ensure the best accuracy it is recommended to set/verify the torque output on a torque tester (with appropriate rundown joint installed).

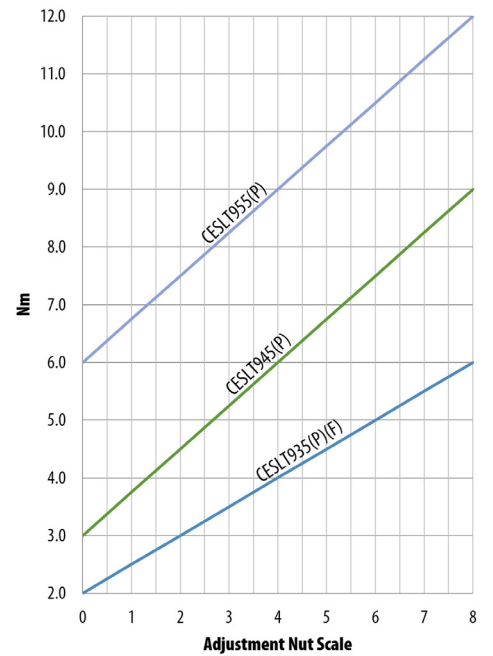
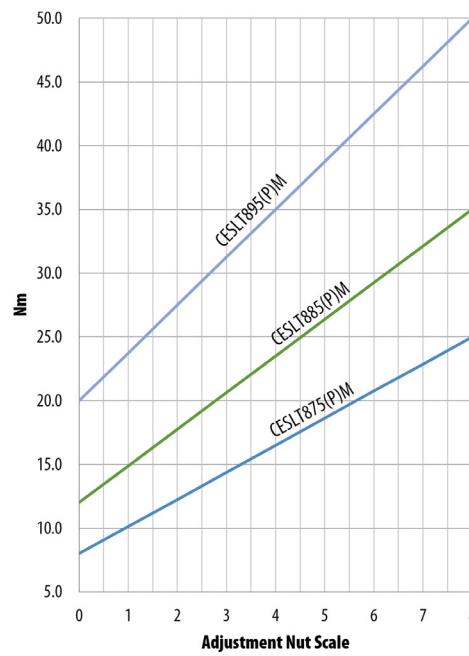
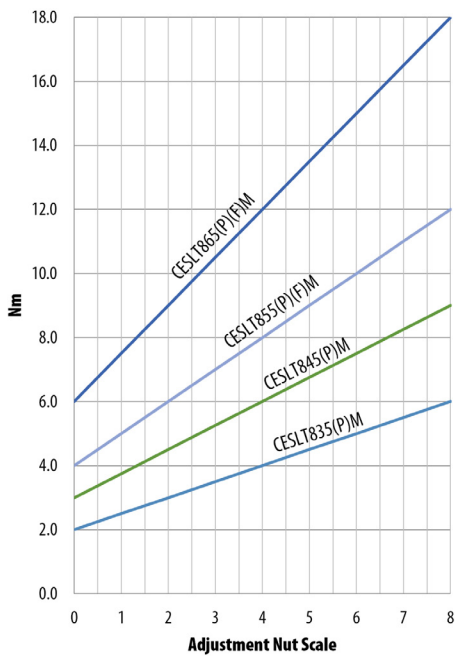
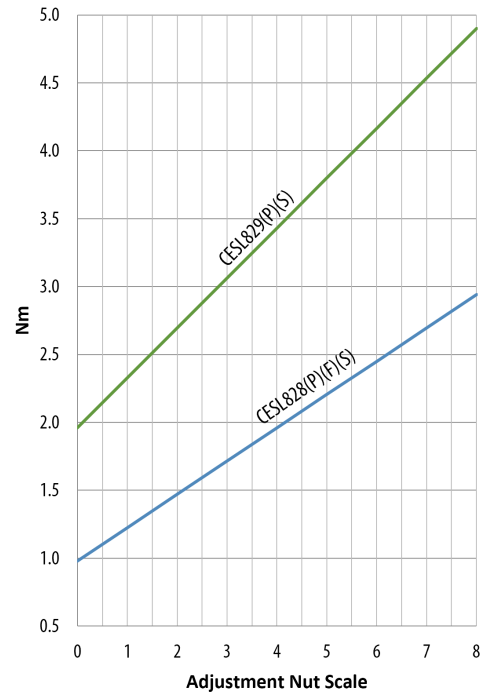
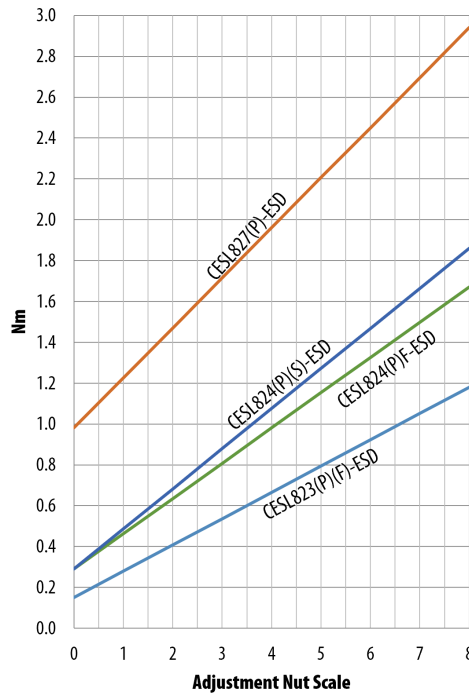
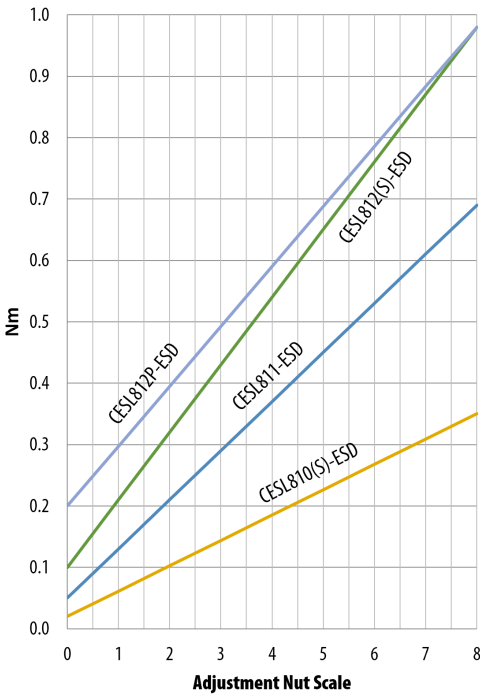

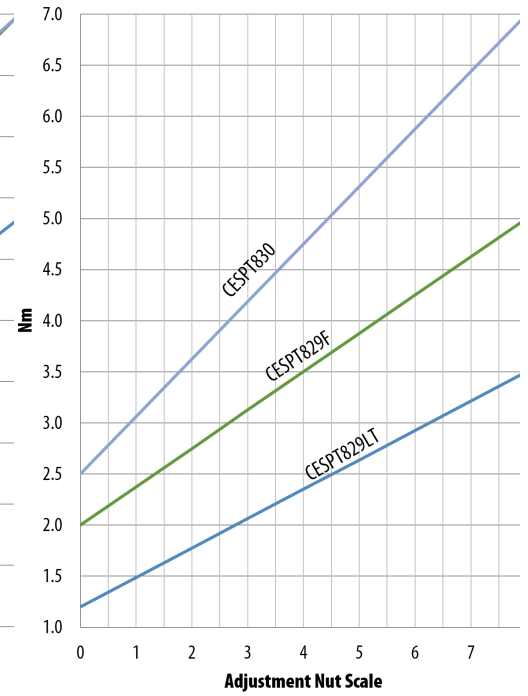
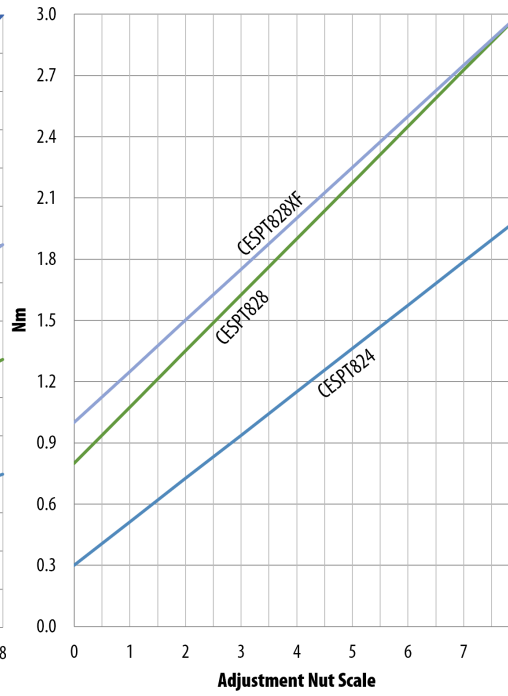
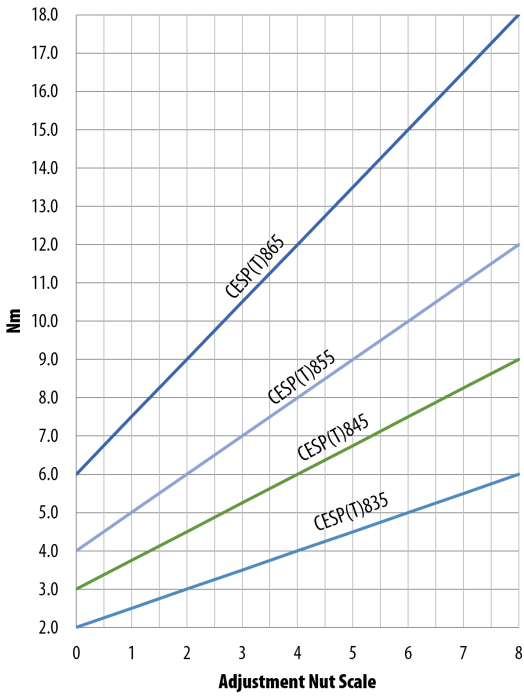

### Torque Adjusting Nut

Turn CW to increase torque setting, CCW to decrease torque output. Higher values on scale indicate a higher torque setting.  
Please note - Numbers (1-8) on the scale are for reference only and are not actual torque values.

### Start Lever

Press to start the screwdriver and hold until the driver shuts off (CW tightening).

### Suspension Bail

Use the bail to hang the screwdriver from a tool balancer.

### Bit Holder

Retract sleeve to insert/remove bits. Once the bit is inserted, release the sleeve and pull back and forth on the bit to verify proper retention.

### Housing Nut

Remove the housing nut to install a torque locking sleeve. The lock sleeve covers the torque adjusting nut to deter unintentional changes to the adjustment.

### FWD/REV Switch

Select the desired direction of rotation for the screwdriver - FWD (CW) or REV (CCW). Some models also have an OFF position.

### Tool Cable Connection

Align the pins of the cable with the socket and push the cable's connector firmly into place. Carefully hand tighten the securing ring - do not over-tighten.



## Model Numbers and Specifications - 32VDC CESL8 Screwdrivers

Model Number		Start Type	Torque Range		Speed (rpm)	Driver Bit Type	Length mm / in	Diameter mm / in	Weight g / lbs
Standard Housing	ESD Housing		in-lbs	Nm					
—	<b>CESL810-ESD</b>	Lever	0.2–3.1	0.02–0.35	1000 / 700	1/4" hex*	185 / 7.3	32 / 1.3	385 / 0.8
—	<b>CESL810S-ESD</b>				500 / 350				
—	<b>CESL811-ESD</b>		0.4–6.2	0.05–0.69	1000 / 700				
—	<b>CESL812-ESD</b>		0.9–8.7	0.1–0.98	1000 / 700				
—	<b>CESL812S-ESD</b>				280				
—	<b>CESL812P-ESD</b>	Push	1.8–8.7	0.2–9.8	1000 / 700				
<b>CESL823</b>	<b>CESL823-ESD</b>	Lever	1.3–10.5	0.15–1.18	1000 / 700	1/4" hex	245 / 9.6	36 / 1.4	520 / 1.1
<b>CESL823P</b>	<b>CESL823P-ESD</b>	Push							
<b>CESL823F</b>	<b>CESL823F-ESD</b>	Lever							
<b>CESL823PF</b>	<b>CESL823PF-ESD</b>	Push			2000				
<b>CESL824</b>	<b>CESL824-ESD</b>	Lever	2.6–16.5	0.29–1.86	1000 / 700				
<b>CESL824S</b>	<b>CESL824S-ESD</b>				500				
<b>CESL824P</b>	<b>CESL824P-ESD</b>	Push			1000 / 700				
<b>CESL824PS</b>	<b>CESL824PS-ESD</b>				500				
<b>CESL824F</b>	<b>CESL824F-ESD</b>	Lever	2.6–14.7	0.29–1.67	2000				
<b>CESL824PF</b>	<b>CESL824PF-ESD</b>	Push							
—	<b>CESL827B-ESD**</b>	Lever	8.7–26.0	0.98–2.94	1200 / 900	1/4" hex	278 / 10.9	39.5 / 1.6	800 / 1.8
—	<b>CESL827BP-ESD**</b>	Push							

\*Drivers available with optional 4mm round (winged bit) bit holder — Add suffix '-4mm' to model number

\*\*CESL827B(P)-ESD is for hard joint, non-prevailing torque applications below 20% duty cycle. Use 40V model CESL828 for more demanding requirements.

## Model Numbers and Specifications - 40VDC CESL(T)8 Screwdrivers

Model Number*	Start Type	Torque Range		Speed (rpm)	Drive Type	Length mm / in	Diameter mm / in	Weight kg / lbs
		in-lbs	Nm					
<b>CESL828S</b>	Lever	8.9–26.0	0.98–2.94	350	1/4" hex	278	39.5	0.8 / 1.76
<b>CESL828PS</b>	Push							
<b>CESL828</b>	Lever			1000				
<b>CESL828P</b>	Push							
<b>CESL828F</b>	Lever			2000				
<b>CESL828PF</b>	Push							
<b>CESL829S</b>	Lever	17.4–43.4	1.96–4.90	350				
<b>CESL829PS</b>	Push							
<b>CESL829</b>	Lever			1000				
<b>CESL829P</b>	Push							

\*ESD-safe housing available — add suffix '-ESD'



Model Number*	Start Type	Torque Range		Speed (rpm)	Drive Type	Length mm / in	Diameter mm / in	Weight kg / lbs
		in-lbs	Nm					
CESLT835M	Lever	18-53	2-6	1200	1/4" hex**	297 / 11.7	46.2 / 1.81	1.25 / 2.75
CESLT835PM	Push							
CESLT845M	Lever	27-79	3-9	900				
CESLT845PM	Push							
CESLT855M	Lever	36-106	4-12	600				
CESLT855PM	Push							
CESLT855FM	Lever			880				
CESLT855PFM	Push							
CESLT865M	Lever	53-159	6-18	370				
CESLT865PM	Push							
CESLT865FM	Lever			600				
CESLT865PFM	Push							
CESLT875M	Lever	71-221	8-25	370				
CESLT875PM	Push							
CESLT885M-SQ***	Lever	106-310	12-35	350	3/8" Square	393 / 15.5	52.7 / 2.07	2.2 / 4.85
CESLT885PM-SQ***	Push							
CESLT895M-SQ***	Lever	177-443	20-50	200	1/2" Square			
CESLT895PM-SQ***	Push							

\*ESD-safe housing available — add suffix '-ESD'

\*\*3/8" Square Drive Available — add suffix '-SQ'

\*\*\*not intended for soft joint applications

## Model Numbers and Specifications - 40VDC CESL9 Screwdrivers

Model Number*	Start Type	Torque Range		Speed (rpm)	Drive Type	Length mm / in	Diameter mm / in	Weight kg / lbs
		in-lbs	Nm					
CESLT935	Lever	18-53	2-6	1000	1/4" hex	306 / 12	41.4 / 1.6	1.03 / 2.3
CESLT935P	Push							
CESLT935F	Lever			2200				
CESLT935PF	Push							
CESLT945	Lever	27-79	3-9	1000				
CESLT945P	Push							
CESLT955	Lever	53-106	6-12	880				
CESLT955P	Push							

\*ESD-safe housing available — add suffix '-ESD'



METAL HOUSING THREAD (M35 x 1.0) FOR  
FIXTURE MOUNT APPLICATIONS

### Fixture Mounting

The CESLT9 Series screwdriver has a threaded metal housing to facilitate fixture mounting. Remove the housing nut to expose the M35 x 1.0 thread.

## Model Numbers and Specifications - 40VDC CESP(T)8 Screwdrivers

Model Number*	Torque Range		Speed (RPM)	Screw Diameter (mm)		Size (L x H)	Weight
	in-lbs	Nm		Machine	Tapping		
<b>CESPT824</b>	2.7-17.7	0.3-2	1200	2.3-3.5	2.3-3.0	185 x 150 mm (7.3 x 5.9")	0.7 kg (1.5 lbs)
<b>CESPT828</b>	7.1-26.5	0.8-3	1200	2.6-4.0	2.6-3.5		
<b>CESPT828XF</b>	8.8-26.5	1-3	3300				
<b>CESPT829LT</b>	10.6-31.0	1.2-3.5	1700				
<b>CESPT829</b>	17.7-44.3	2-5	700	4.0-5.0	≤4		
<b>CESPT829F</b>			1000				
<b>CESPT830</b>	22.1-62.0	2.5-7	850	5.0-6.0	≤5		

\*Standard model has cable connection in bottom of handle — for top connection, add suffix 'U'. For ESD-safe housing, add suffix 'ESD'.

Model Number*	Torque Range		Speed (rpm)	Drive Type**	Size (L x H x dia)	Weight
	in-lbs	Nm				
<b>CESP(T)835</b>	18-53	2-6	1000	1/4" hex	270 x 169 x 48 mm (10.6 x 6.7 x 1.9")	1.2 kg (2.64 lbs)
<b>CESP(T)845</b>	27-79	3-9	800			
<b>CESP(T)855</b>	36-106	4-12	550			
<b>CESP(T)865</b>	53-159	6-18	350			

\*Standard model has cable connection in bottom of handle — for top connection, add suffix 'U'. For ESD-safe housing, add suffix 'ESD'.

\*\*3/8" Square Drive available — add suffix '-SQ'

## Right Angle Series Brushless

# Angle Attachment

## Converts Inline Screwdriver to 90° angle driver

Contents	
1 pc	Angle Attachment
1 pc	#1 Phillips bit
1 pc	#2 Phillips bit
1 pc	Hex extension bit
1 pc	1.5mm hex key

DR80-10160B & DR80-10161B  
Angle Head Attachments

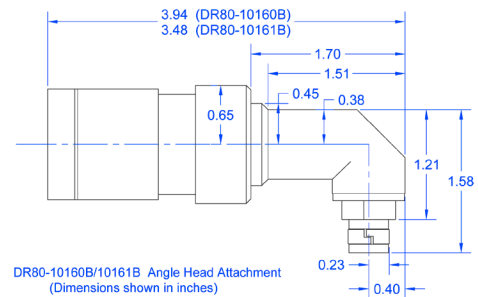

### STEP 1

Remove the C-Ring from the front of tool.



### STEP 2

Unthread the torque adjusting nut from the driver.



### STEP 3

Insert the hex extension bit into the bit retainer of the



### STEP 4

Remove the set screws on the angle attachment to prevent damage to the threads.

Note: Always loosen set screws when adjusting torque value.

### STEP 5

Screw the angle attachment onto the front of the driver (the torque adjusting nut is not required when the angle attachment is installed). Take care to align the hex extension from the driver with the female hex drive of the anglehead during this process.

### STEP 6

Set the desired torque.

Note: that the scale is for reference only and is not an indication of torque.



### STEP 7

Tighten set screws into the angle attachment.

**DO NOT OVERTIGHTEN!**



### STEP 8

Loosen upper ring on the angle attachment, pull then rotate head to desired orientation, align pins with nearest holes and tighten ring.



\* Use of the angle head attachment will reduce the drivers torque output. Please contact Delta Regis Tools, Inc. for further information.

## CESLT8\_M/RAS ANGLE DRIVER Torque Adjustment

### Overview

Right angle screwdriver models CESLT835M/RAS - CESLT875M/RAS incorporate a torque adjustment nut which is protected by a metal cover. Two capscrews are installed into the adjustment nut to lock the setting and prevent the angle head from loosening off during use. The /RAS suffix signifies square drive output, a /RAH suffix is used for 1/4" hex drive bit holder versions.

The following procedure outlines how to make changes to the torque setting of the driver.

**CAUTION:** After adjustments are made, the METAL COVER MUST BE INSTALLED in place over the torque adjustment nut before putting the driver into service. The male threads which secure the torque cover in place may have sharp edges - do not place your hands on these threads when making adjustments or running the screwdriver.



### REMOVE THE ANGLE HEAD

Loosen the angle head securing nut by hand and remove the angle head assembly as shown below. An internal hex bit connects the output drive of the screwdriver to the input drive of the angle head. Two pins allow the angle head to be aligned in the desired orientation to the tool trigger when re-assembling.



## REMOVE LOCKING SCREW & TORQUE COVER

Using the supplied hex key, remove the two locking cap screws (180 degrees apart) from the front of the torque adjusting nut. Once the cap screws are removed, unscrew the torque adjustment cover by hand and remove.



## REINSTALL THE ANGLE HEAD AND ADJUST TORQUE

- Install the angle head without the cover in place and tighten the angle head retaining nut by hand. Adjust the torque setting by turning the torque adjustment nut CW to increase torque (covering higher numbers on the scale) or CCW to decrease torque. Always make adjustments from a lower torque setting to a higher setting. Adjustments must be left at a detented (mechanical click) position. Insert cap screws to lock adjustment and test the screwdriver for proper torque on an appropriate torque tester. Repeat the adjustment process (remove lock screws, adjust, install lock screws) until the desired torque setting is achieved.
- **Note:** There are two sets of threaded holes for installing the locking cap screws. One set of holes will align with recessed grooves in the clutch housing underneath the adjustment nut, depending on the position of the torque adjustment nut. Use the set of holes that properly align with the grooves when reinstalling the locking screws.



## REINSTALL THE TORQUE ADJUSTMENT COVER

Once the desired torque has been set, remove the angle head. Temporarily remove the cap screws locking the torque adjustment and re-install the torque adjustment cover, tightening by hand. Install the torque locking cap screws into the holes aligning with the recessed grooves and secure. Install the angle head in the desired orientation and secure the retaining nut by hand. The driver is now ready to use.



## Model Numbers and Specifications - 40VDC CESL(T)8 Right Angle Screwdrivers



Model Number (Standard Housing)	Model Number (w/ ESD Housing)	Torque Range		Speed (rpm)	Weight g / lbs
		in-lbs	Nm		
CESL823/RA	CESL823-ESD/RA	0.9–7.3	0.11–0.83	1000/700	770 / 1.7
CESL823F/RA	CESL823F-ESD/RA	0.9–7.3	0.11–0.83	2000	
CESL824/RA	CESL824-ESD/RA	1.8–11.6	0.20–1.30	1000/700	
CESL824F/RA	CESL824F-ESD/RA	1.8–10.4	0.20–1.17	2000	
—	CESL827B-ESD/RA	6.0–18.2	0.68–2.06	1200/900	1050 / 2.3

Model Number (Standard Housing)	Model Number (w/ ESD Housing)	Torque Range		Speed (rpm)	Drive Type	Weight kg / lbs
		in-lbs	Nm			
CESL828/RA	CESL828-ESD/RA	8.9–19	0.98–2.15	1000	1/4" hex	0.77 / 1.7
CESL828F/RA	CESL828F-ESD/RA	8.9–19	0.98–2.15	2000		
CESL829/RA	CESL829-ESD/RA	17.4–32	1.96–3.61	1000		
CESLT835M/RAS	CESLT835M-ESD/RAS	18–45	2–5	1200	3/8" square*	1.77 / 3.9
CESLT845M/RAS	CESLT845M-ESD/RAS	27–67	3–7.5	900		
CESLT855M/RAS	CESLT855M-ESD/RAS	53–90	6–10	600		
CESLT855FM/RAS	CESLT855FM-ESD/RAS	53–90	6–10	880		
CESLT865M/RAS	CESLT865M-ESD/RAS	71–145	8–15	370		
CESLT865FM/RAS	CESLT865FM-ESD/RAS	71–145	8–15	600		
CESLT875M/RAS	CESLT875M-ESD/RAS	106–195	12–22	370		

\*1/4" hex available — Replace "/RAS" suffix with "/RAH"

The Delta Regis 40VDC 90° Right Angle Drivers have a low-profile angle head attachment for applications with limited clearance. The right angle design provides the operator with a long handle to react the torque. CE/RoHS compliant.

## Torque Reference Charts

### Important Note

The charts below are provided to assist in setting your screwdriver to an approximate torque value. Actual results may vary from tool to tool. In order to ensure the best accuracy it is recommended to set/verify the torque output on a torque tester (with appropriate rundown joint installed).

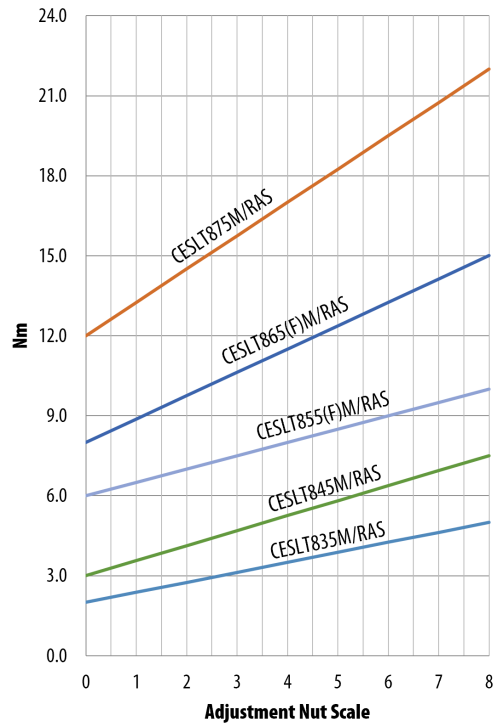
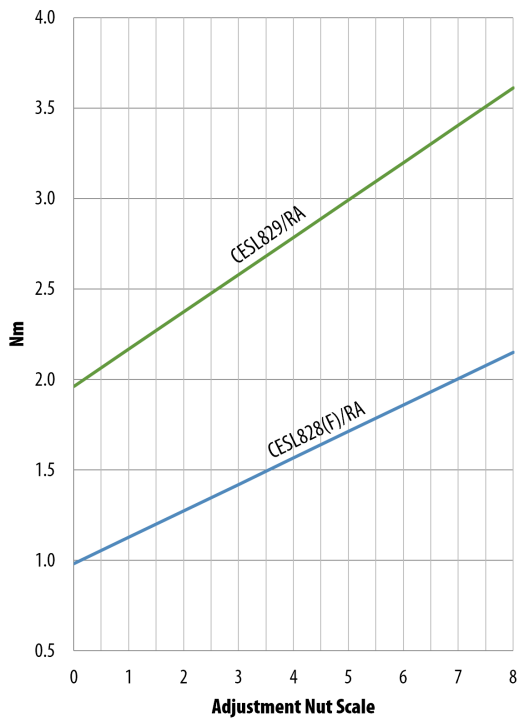



## Slow Start / Output Signal Modules

Optional modules are available to add slow start and I/O functionality to the standard CESL8 tool and controller. These modules plug in-line between the controller and the screwdriver. All modules offer adjustable slow start (0-9.9 sec, 30~100% of full speed). Some models include input signal capability to provide further screwdriver control. Please contact us or visit our website for further details on available modules and their features.

## Accessories and Parts

Delta Regis offers various accessories for use with the screwdrivers listed in this manual. Please contact us or visit our website for further details on available accessories.

If you require a parts drawing or replacement spare parts for your Delta Regis product, please call us or send an e-mail request to [sales@deltaregis.com](mailto:sales@deltaregis.com).

## Service

The BECT6 and BECT8/9 Series Controllers are not user serviceable. Any repairs must be performed by a Delta Regis authorized service center. Please consult Delta Regis Tools for further information and the location of the nearest authorized service center. Repairs to CESL8/CESP8/CESLT9 series screwdrivers must be performed by trained personnel, knowledgeable and qualified in the repair of DC electric screwdrivers. Use only genuine Delta Regis parts when servicing these products. Do not attempt to modify the tools or controllers.

## Warranty

The CESL8 and CESLT9 Series Tools and Controllers are warranted for one year from the date of purchase against defects in material and workmanship. In addition, the brushless motor in the CESL8/9 Series Screwdrivers is warranted for three years from the date of purchase against defects in material and workmanship. This warranty does not cover damage due to transportation, abuse, misuse, or improper service. Our sole remedy is to repair or replace (at our discretion) any unit found to be defective due to defects in material or workmanship. It is the responsibility of the user to return any product thought to be defective, freight prepaid, to our warehouse for inspection and evaluation.

There is no warranty of merchantability or fitness of purpose. In no event will Delta Regis Tools, Inc. be liable for business interruptions, loss of profits, harm, injury, damage, personal injury, cost of delay, or any other special, indirect, incidental, or consequential losses, costs, or damages.

