

TRANSDUCERIZED TORQUE CONTROL SYSTEM

The DR-XTC1 Controller allows you to be in full control of your entire fastening process. Easily setup multiple tightening parameters like speed, time, thread, direction & torque through the controller directly or via PC with [deltaOnpoint](#) software installed. Create multiple jobs for different assembly stages and quickly switch between desired job dynamically. Tightening data can be transferred out using the built-in Ethernet Module and can also be stored locally on an SD card to avoid data loss due to untimely internet connectivity issues.

Features

- High precision torque transducer
- Can be programmed for multiple start modes
 - Lever Start
 - Push Start
 - Lever + Push Start
- SD card slot for temporary data storage (Supports up to 32GB)
- Save up to 250 sequences
- Use up to 5 steps per screw tightening
- Save up to 99 steps
- Use up to 50 sequences per job
- Save up to 50 jobs

Experience the added control of real-time settings adjustment & data collection with



deltaOnpoint
DATA CONTROL SOFTWARE by Delta Regis



Specifications		
Model	DR-XTC1	DR-XTC2
Input Voltage	AC 115/230V, 50/60 Hz, 6.3A	
I/O Output Voltage	DC 24V 50mA / 12V 100mA	
Count	1-99	
Count Method	Incremental/Decremental	
Torque Detection Value	Based on Screwdriver Specifications	
Screw Thread Number Detection	0.0-999.9	
External Connection Input	Start/Forward/Reverse/Disable/Confirm	
External Connection Output	OK/NG/OK ALL/Start/Reverse	
Interface	RS-232, Micro SD, LAN, USB, I/O Terminals	
Compatible Software	deltaOnpoint	
External Dimensions	185 x 241.4 x 127 mm (7.3 x 9.5 x 5")	
Weight	2.5 Kg (7.5 lbs)	
Applicable DC screwdriver model	ESL-XTE1/3/5/7 (RAH) Series	ESL-XTE12/18/25 Series

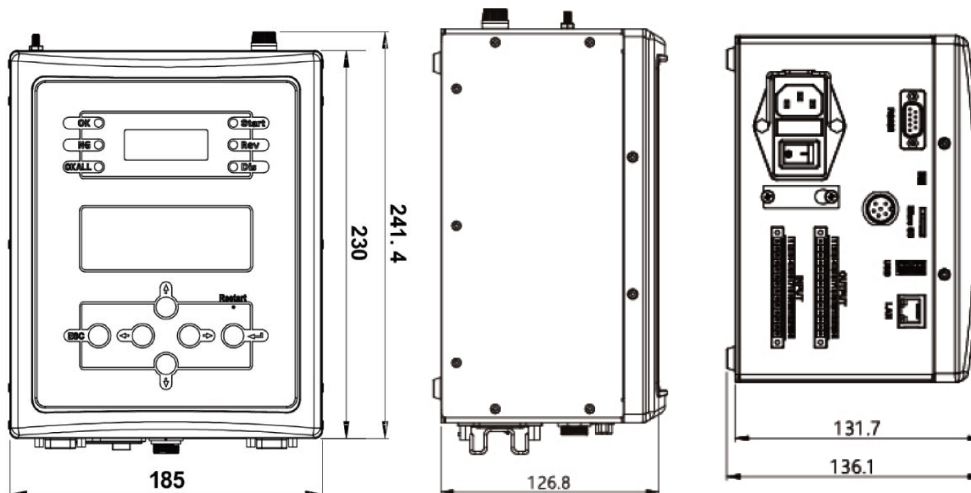

TRANSDUCERIZED TORQUE CONTROL SYSTEM

ESL-XTE Series Inline Transducer Screwdrivers

Specifications									
Model	ESL-XTE1	ESL-XTE3LT	ESL-XTE3F	ESL-XTE5	ESL-XTE7	ESL-XTE12	ESL-XTE18	ESL-XTE25	
Input Voltage	DC40V								
Torque	Nm	0.05-1	0.5-3.0	0.6-3.0	1.0-5.0	1.4-7.0	2.4-12.0	3.6-18	5.0 - 25.0
	in-lbs	0.4-8.8	4.4-26	5-26	9-44	12-62	21-106	31-159	44.2 - 221.2
Max/Min Speed (RPM)	980/100		1600/160	1100/110	660/70	1000/100	600/60	400/40	
Power Consumption	90W								
Weight	682g (1.50 lbs)			830g (1.83 lbs)		1130g (2.49 lbs)		1790g (3.94 lbs)	
Length	280 mm (11.02 in)			297 mm (11.69 in)		313 mm (12.32 in)		325 mm (12.79 in)	
ESD Safe	Yes								
Power Controller	DR-XTC1					DR-XTC2			
Bit Type	1/4" Hex					1/4" Hex (3/8" Square Special Order)			



ESL-XTE3LT

ESL-XTE1/3LT

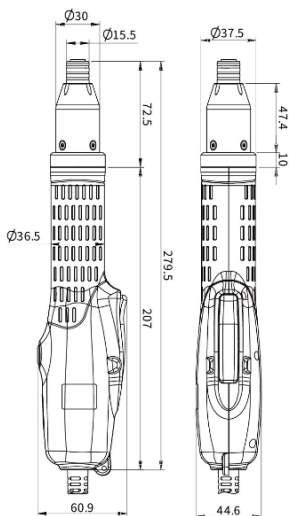

ESL-XTE3F/5/7

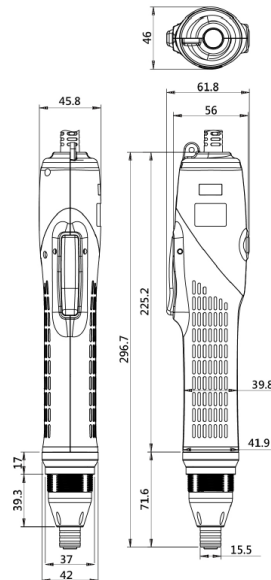

ESL-XTE12/18

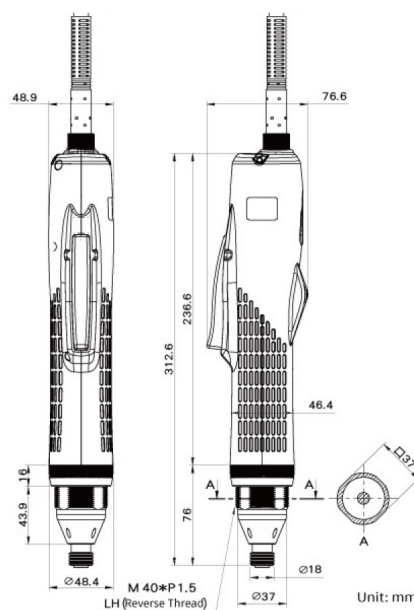

ESL-XTE25

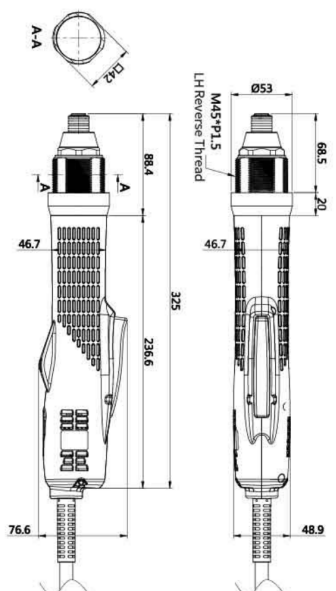

TRANSDUCERIZED TORQUE CONTROL SYSTEM

ESL-XTE Series Right Angle Transducer Screwdrivers

Specifications							
Model	ESL-XTE3/RAH	ESL-XTE5/RAH	ESL-XTE7/RAH	ESL-XTE12/RAH	ESL-XTE18/RAH	ESL-XTE25/RAH	
Input Voltage	DC40V						
Torque	Nm	0.6-3.0	1.0-5.0	1.4-7.0	2.4-12.0	3.6-18.0	5.0-25.0
	in-lbs	5-26	9-44	12-62	21-106	32-159	44-221
Max/Min Speed (RPM)	1100/120	800/80	450/50	1000/100	600/60	400/40	
Power Consumption	90W						
Weight	1150g (2.5 lbs)			2230g (4.9 lbs)		2810g (6.2 lbs)	
Length	330 mm (13 in)			393 mm (15 in)		439 mm (17 in)	
ESD Safe	Yes						
Power Controller	DR-XTC1			DR-XTC2			
Bit Type	1/4" Hex (3/8" Square Special Order)						



ESL-XTE3/RAH

ESL-XTE3,5,7/RAH

ESL-XTE12,18/RAH

ESL-XTE25/RAH

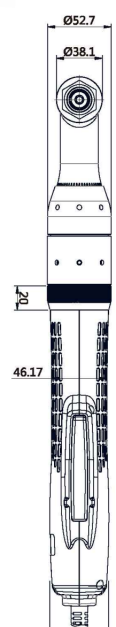
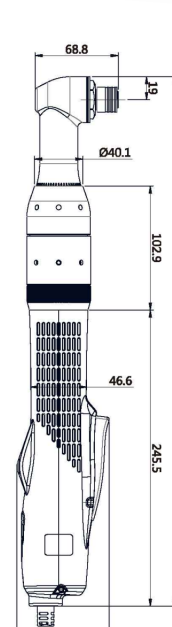
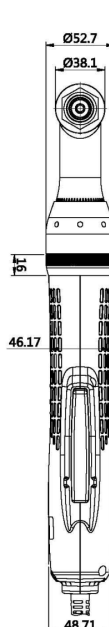
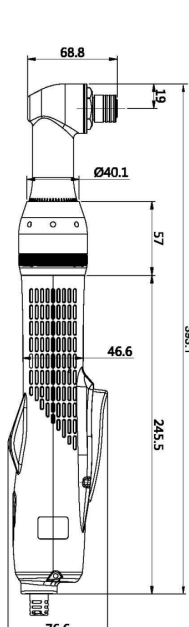
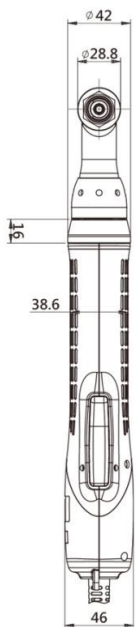
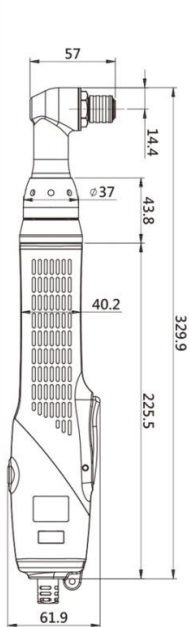

Unit: mm